

shown: DR FML 200-ES, MMR, side, MBR, HWD

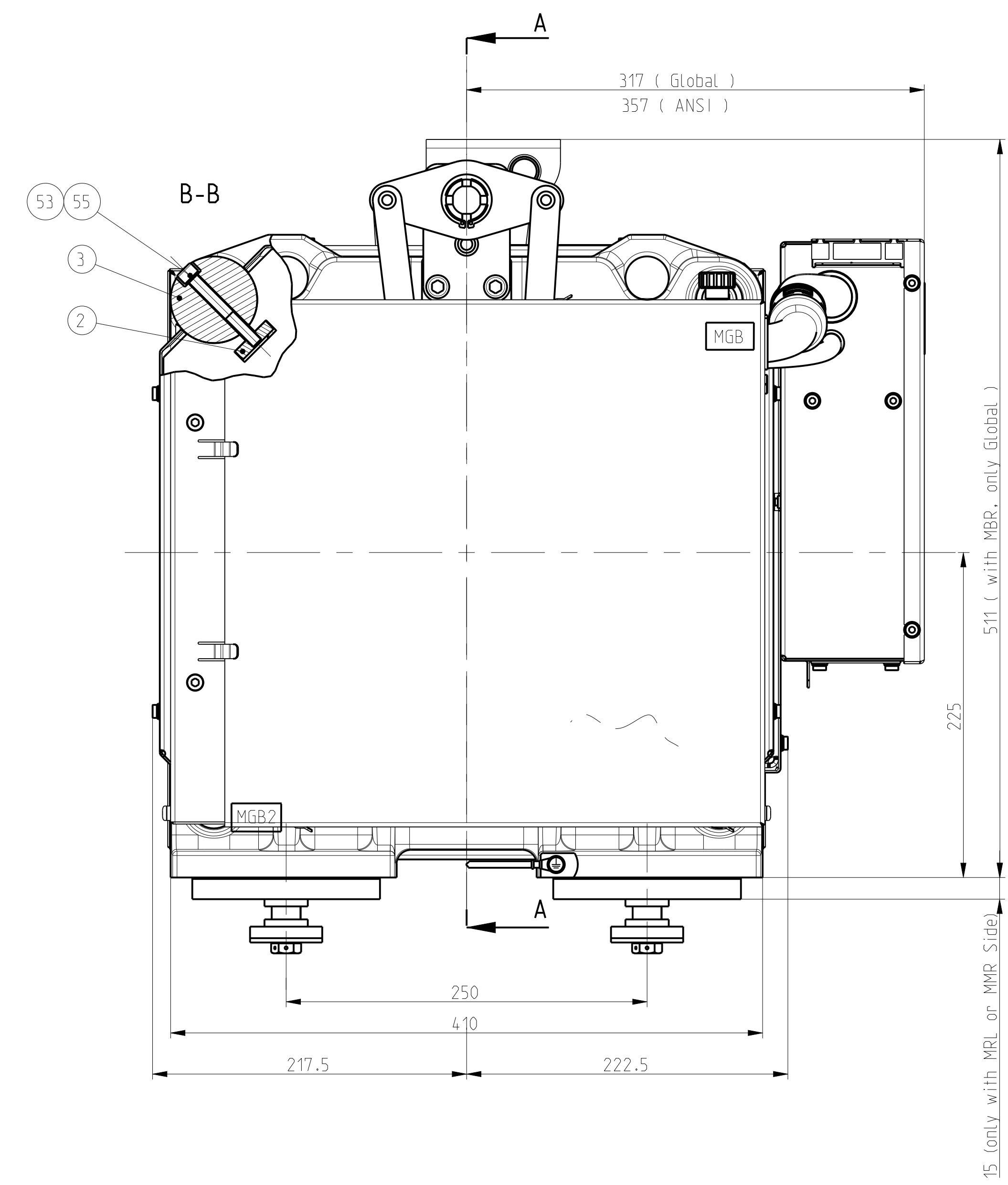

A-A shown: DR FML 200-E, MMR, rear, ANSI

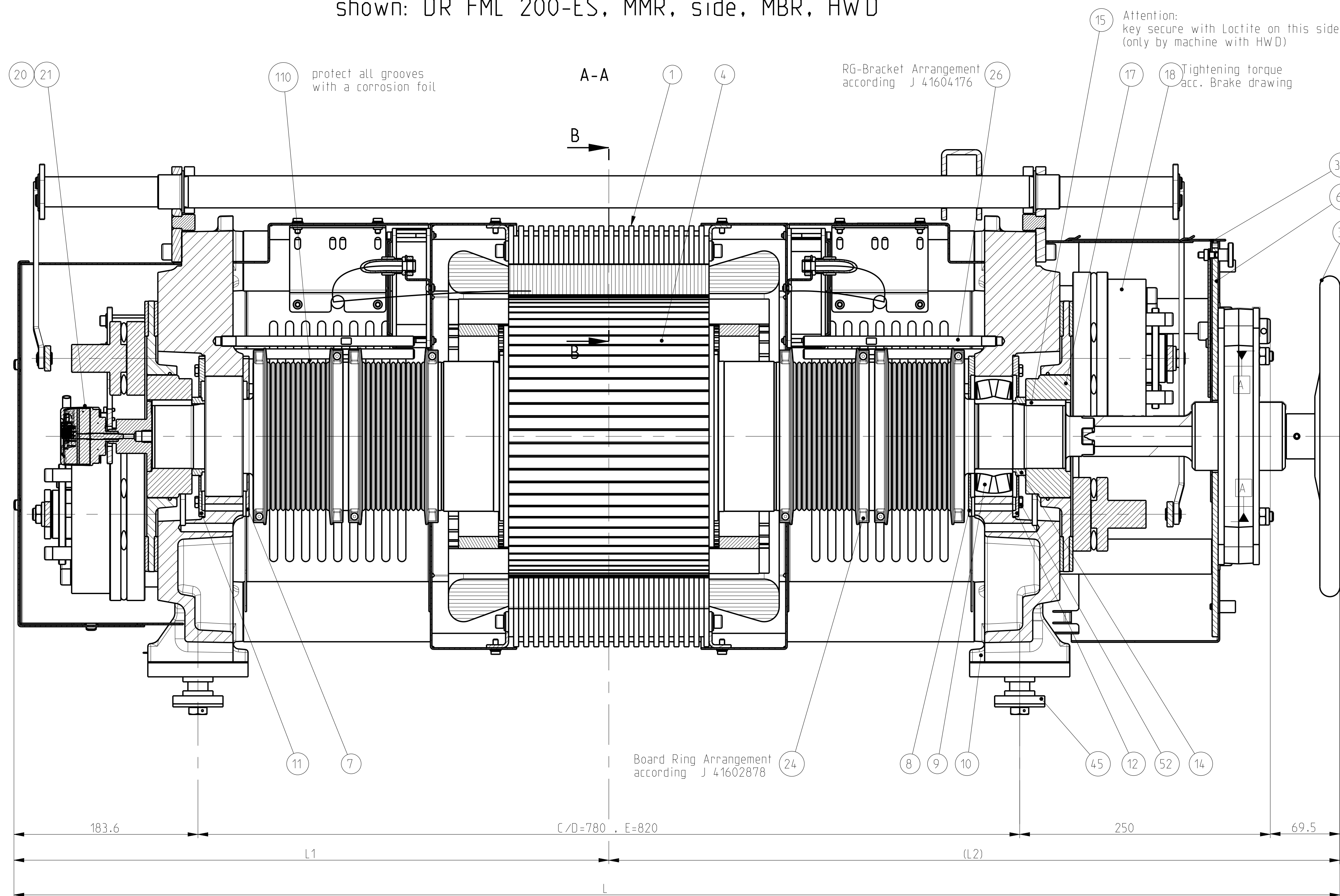
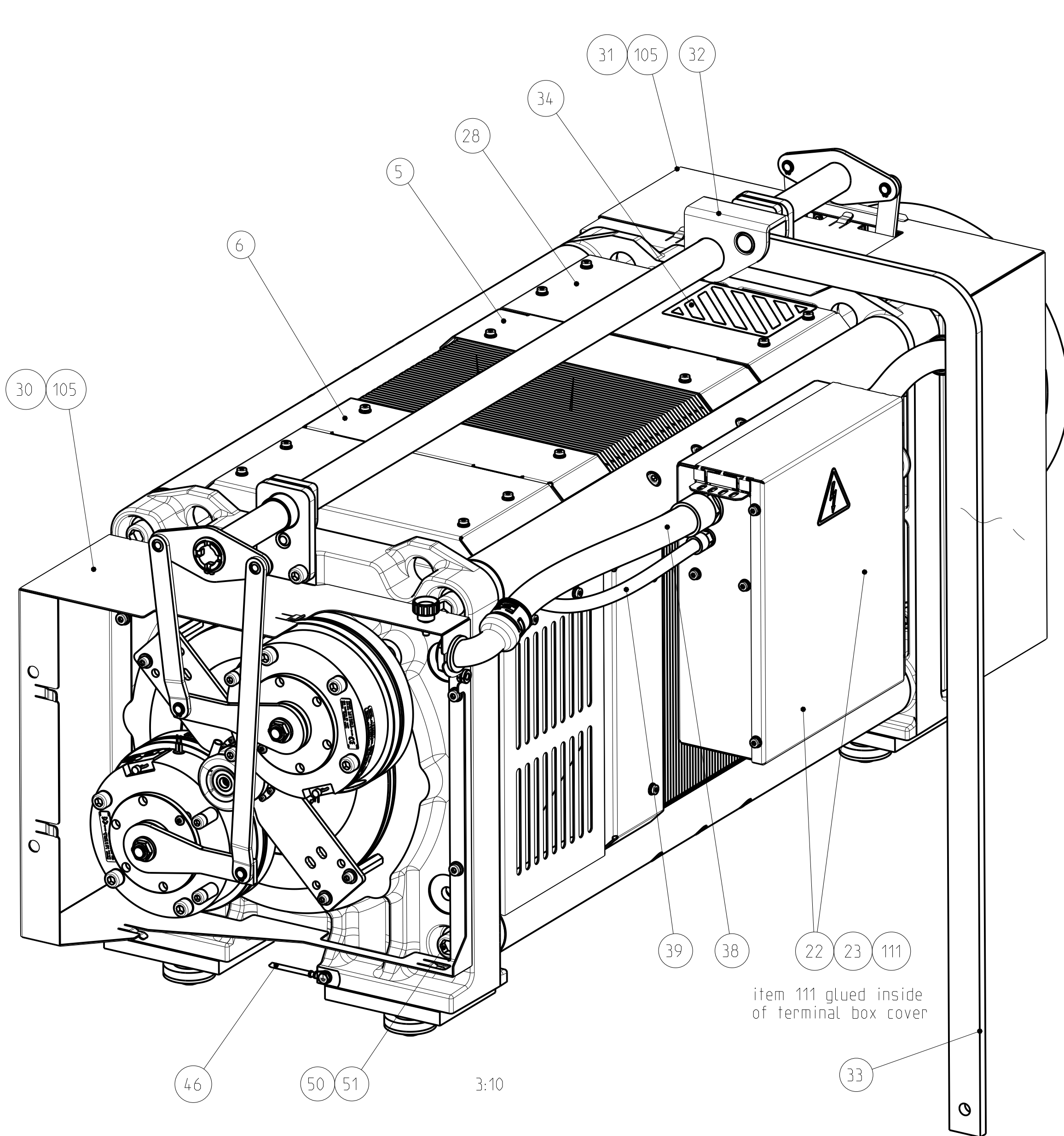
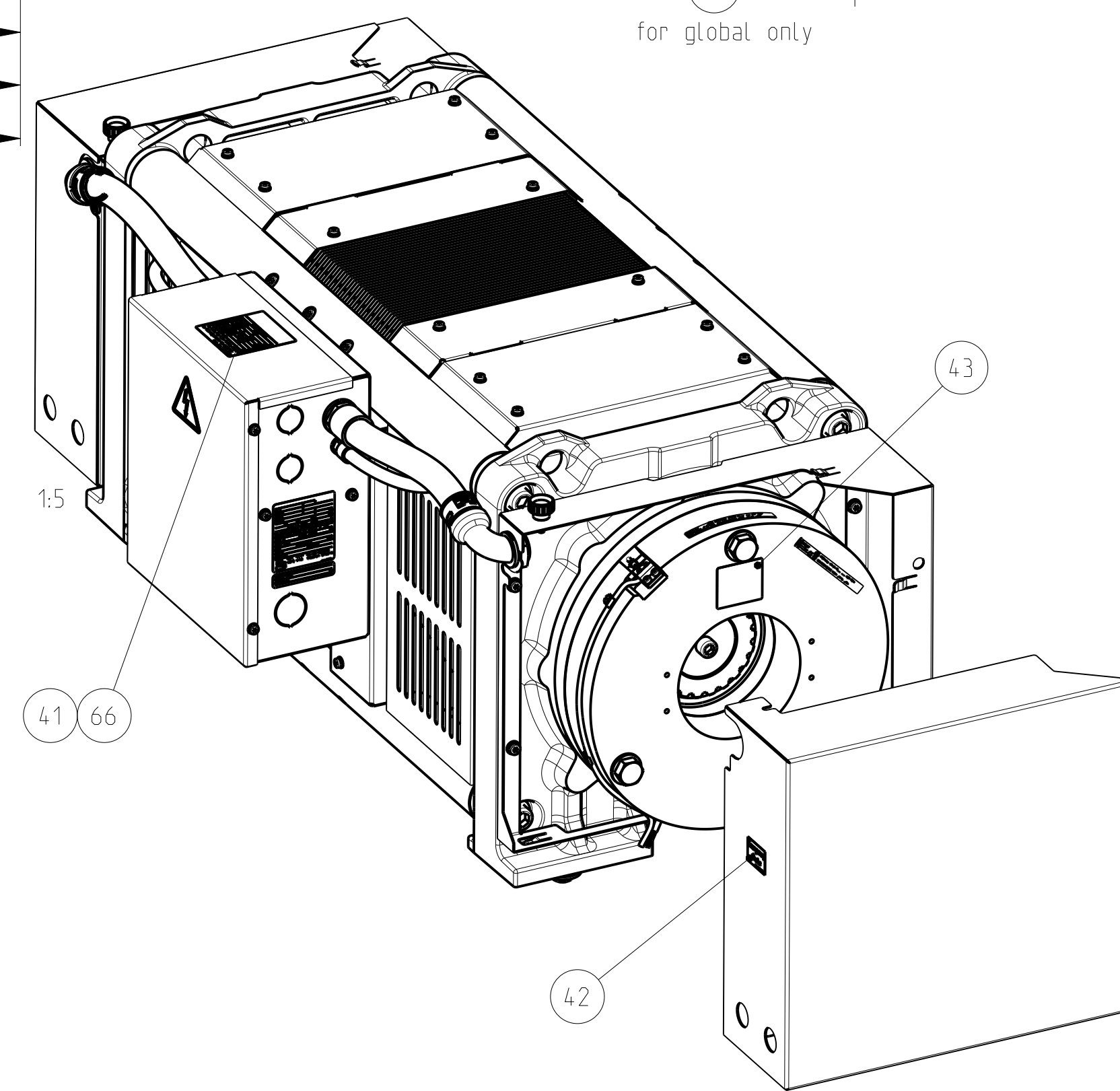
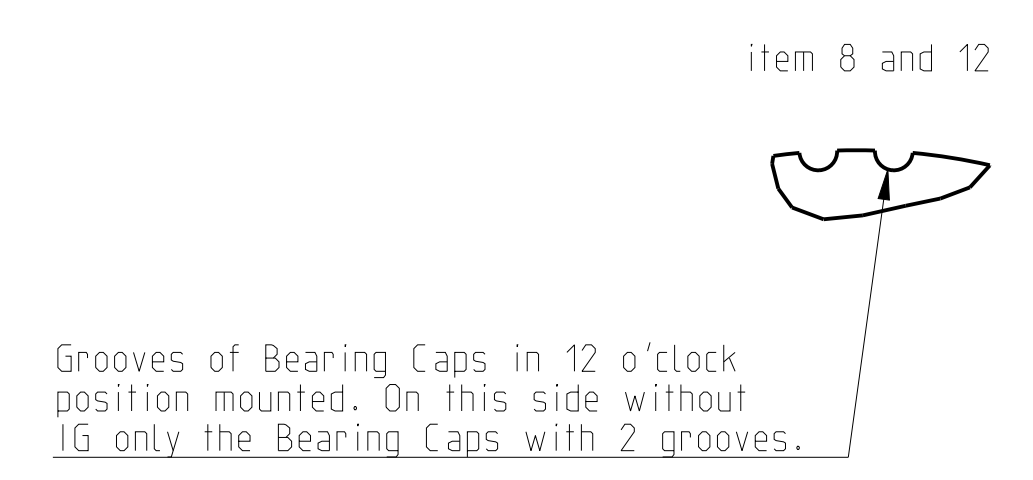
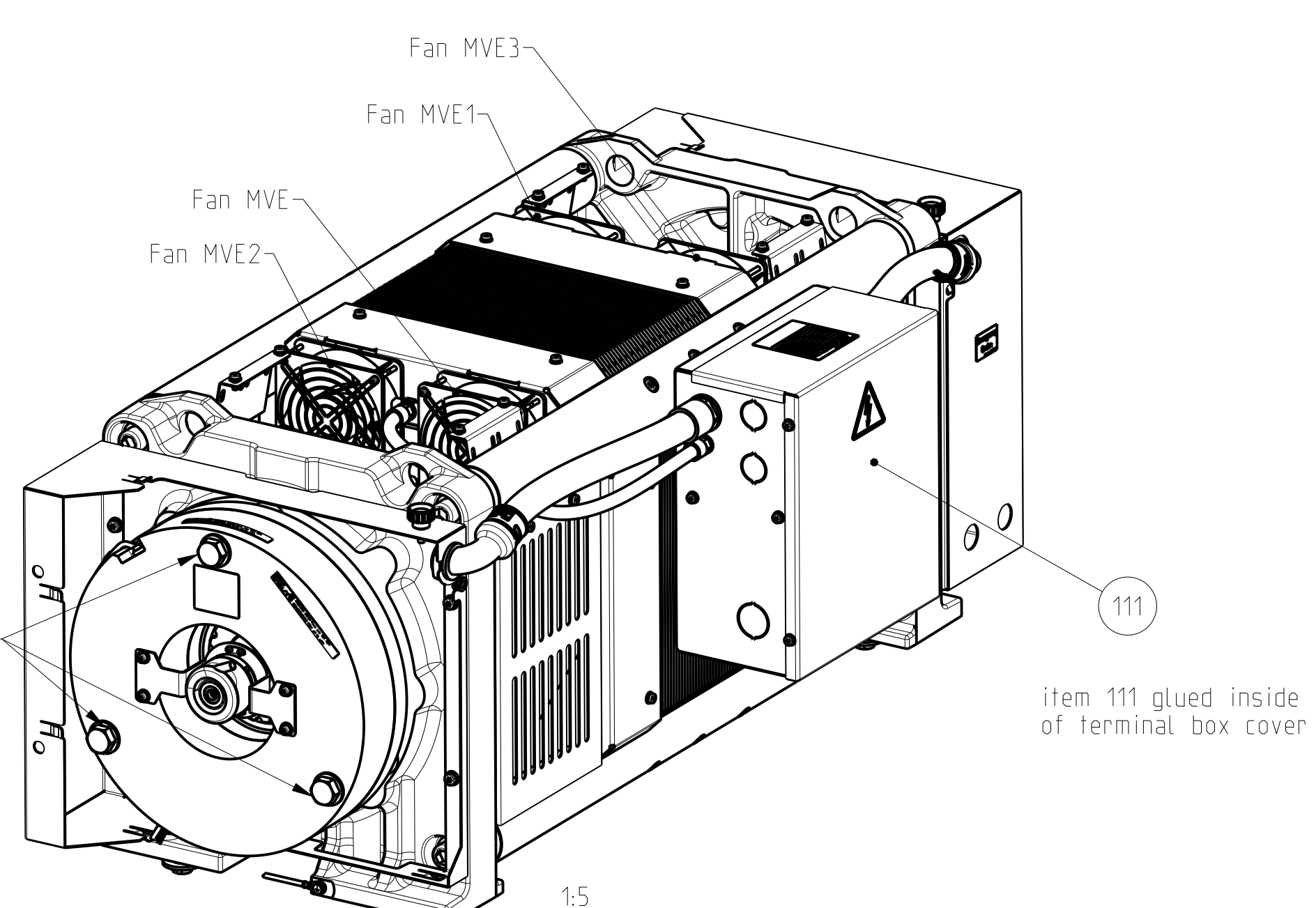
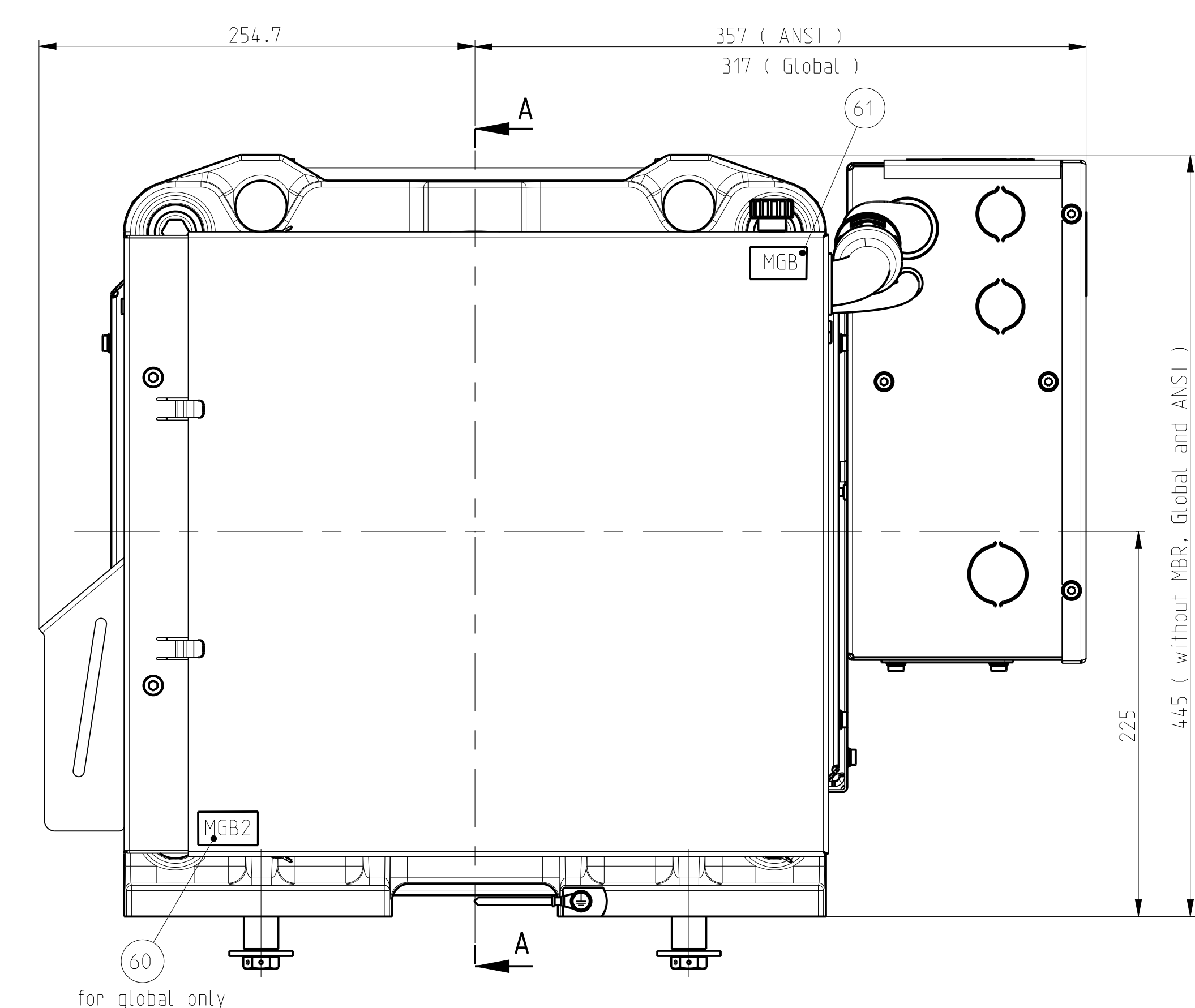
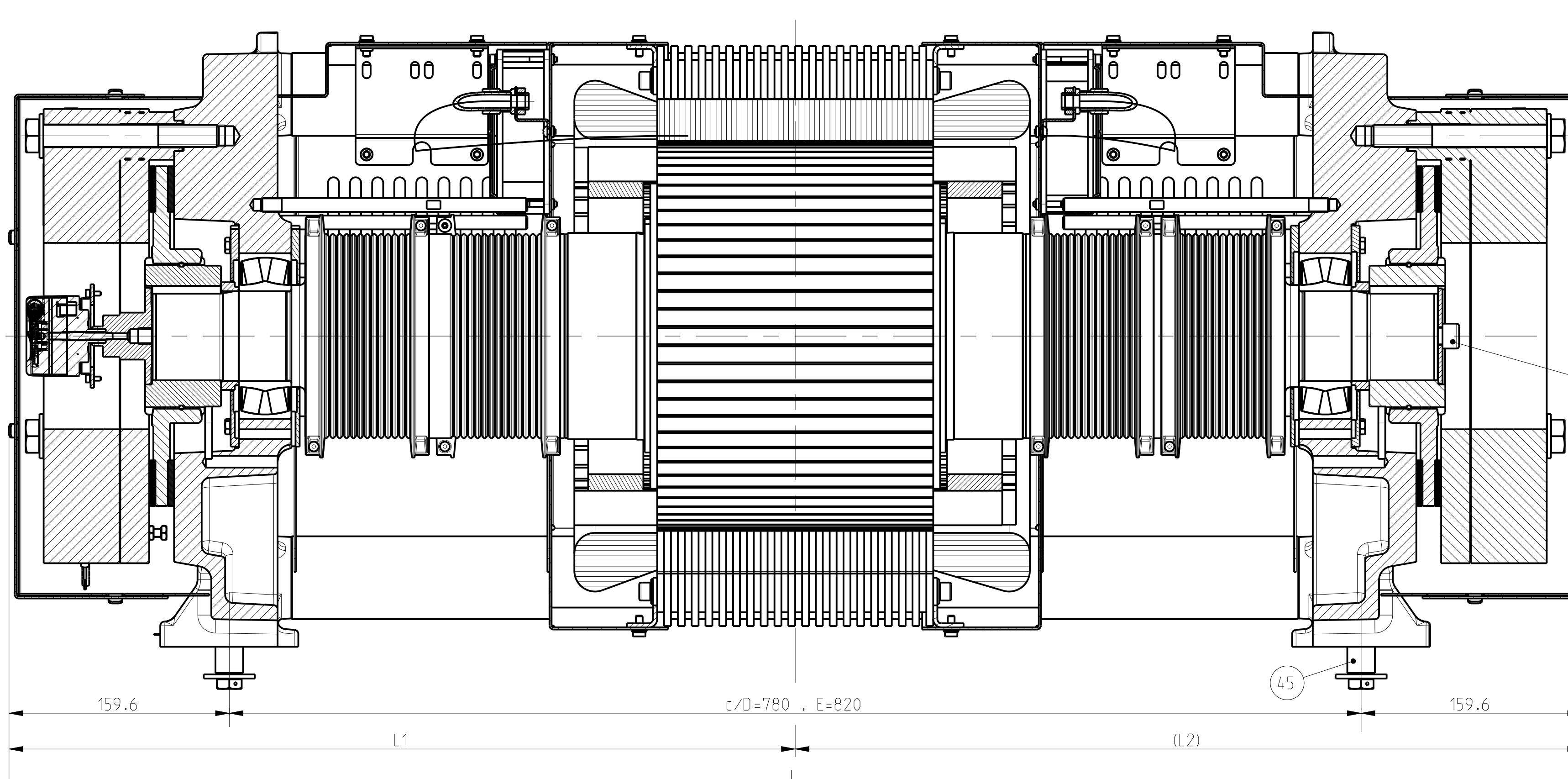
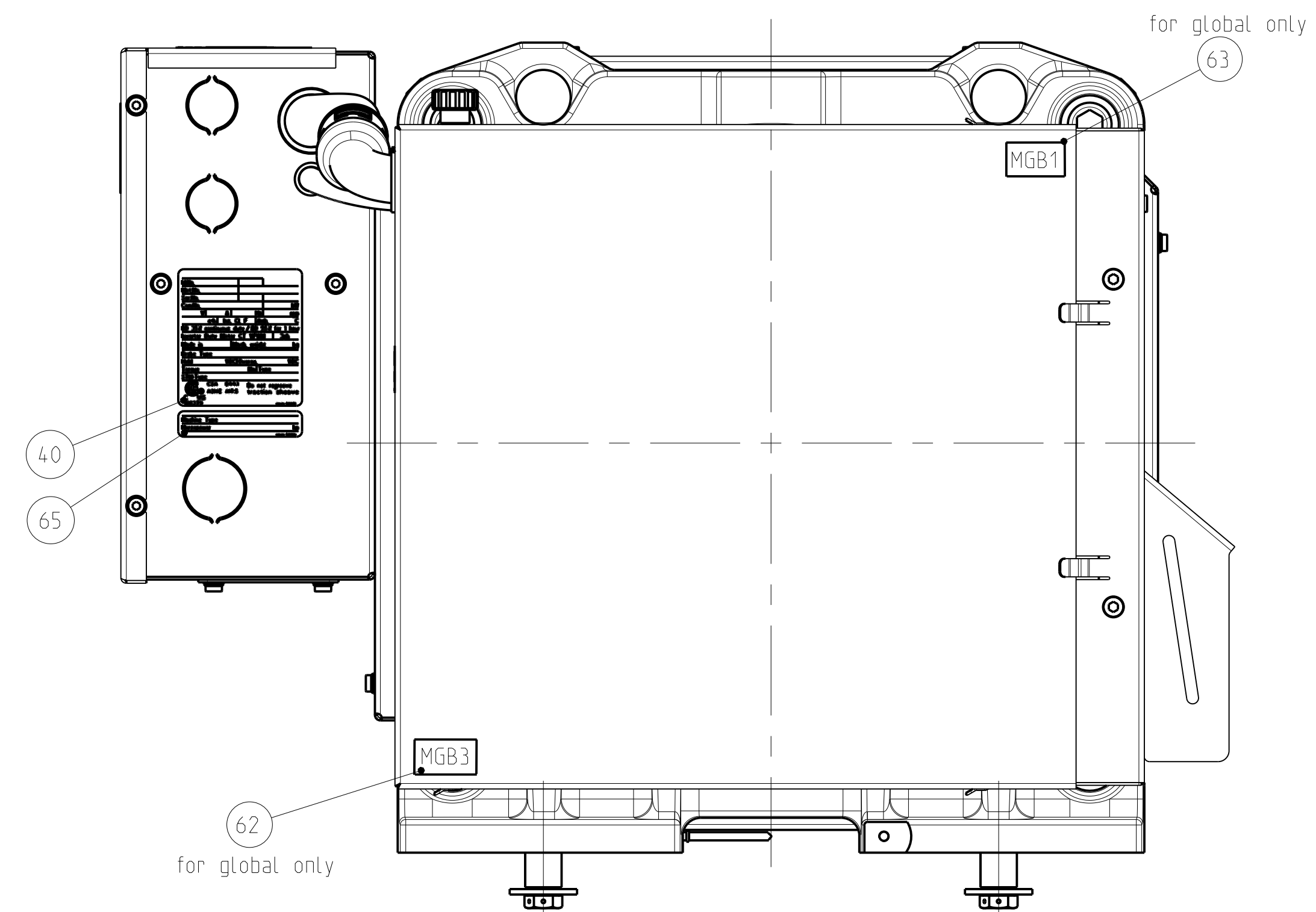

- Check the air cap between rotor and stator by assembling: 0.9 ± 0.2
- Item 64, 100, 101, 102 and 110 not shown on this drawing
- MBR: Manual Brake Releaser
- HWD: Hand Winding Device

FML 200-C/D	1099.2	549.6	549.6	Global and ANSI
FML 200-C/D, MBR	1147.2	573.6	573.6	only Global
FML 200-C/D, MBR, HWD	1283.1	573.6	709.5	only Global
FML 200-E	1139.2	569.6	569.6	Global and ANSI
FML 200-E, MBR	1187.2	593.6	593.6	only Global
FML 200-E, MBR, HWD	1323.1	593.6	729.5	only Global
Machine Typ	L	L1	(L2)	Standard

DR FML 200		Scale		Revision		Date		Name	
1:1		1:1		2022-05-25	schmidt				
1:2		1:2		2022-05-25	hammer				
				2023-05-25	janetti				

INVENTIO AG (H-6052 Hergiswil) Classification: NS1 Scale Office: Z...41604400

shown: DR FML200 CSN2, MRL, Rear (only for Standad ANSI)
only C /D machine

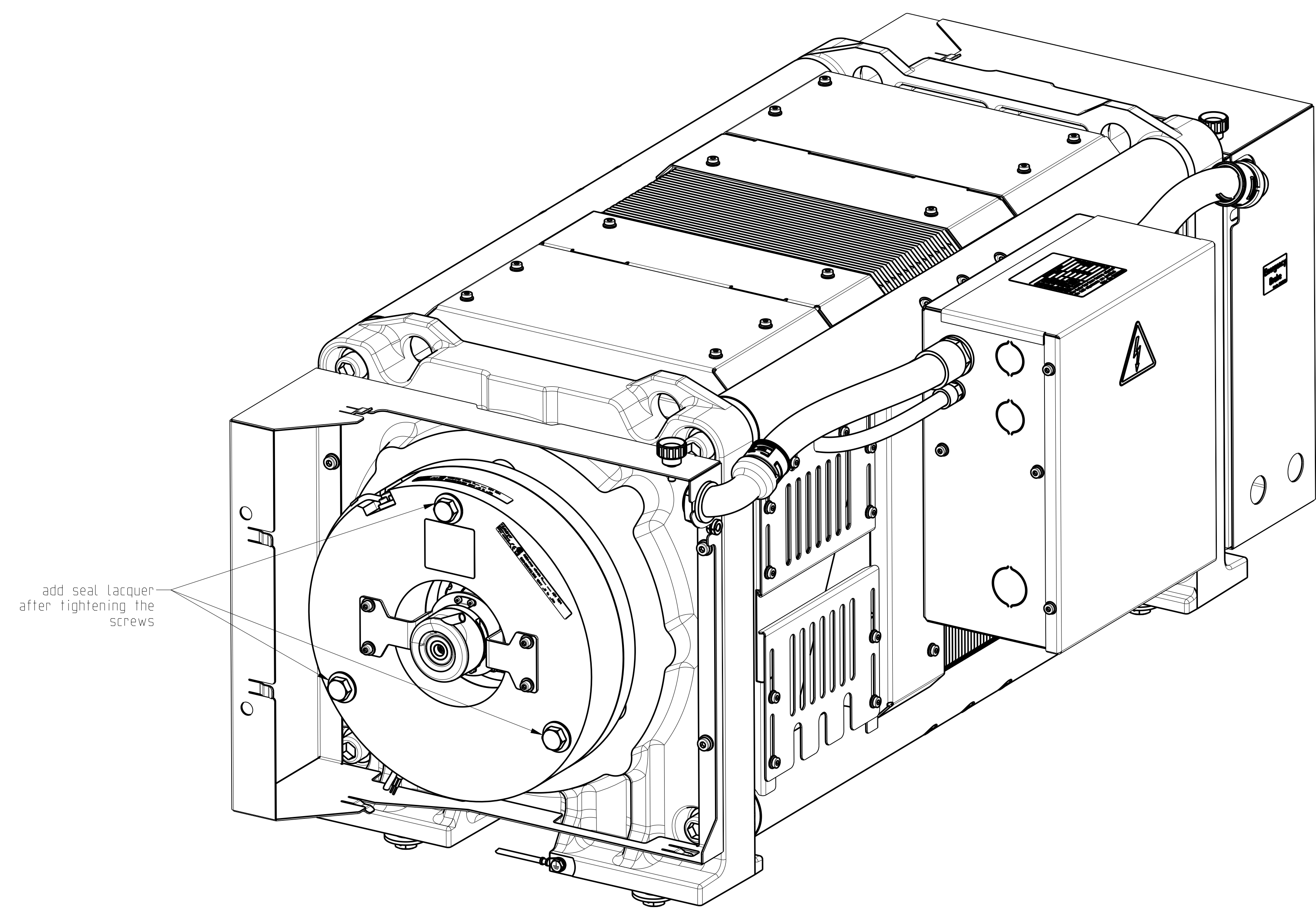
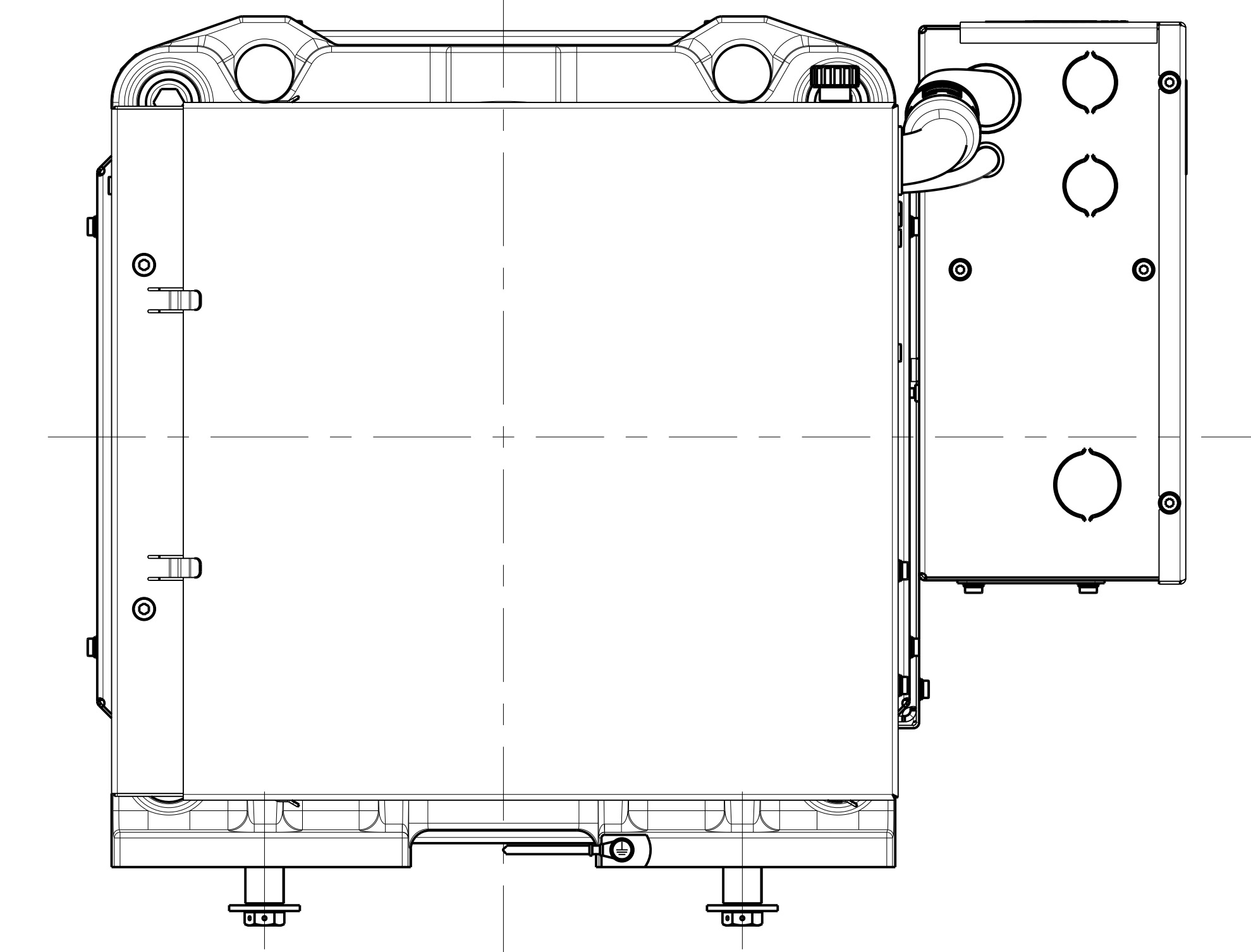
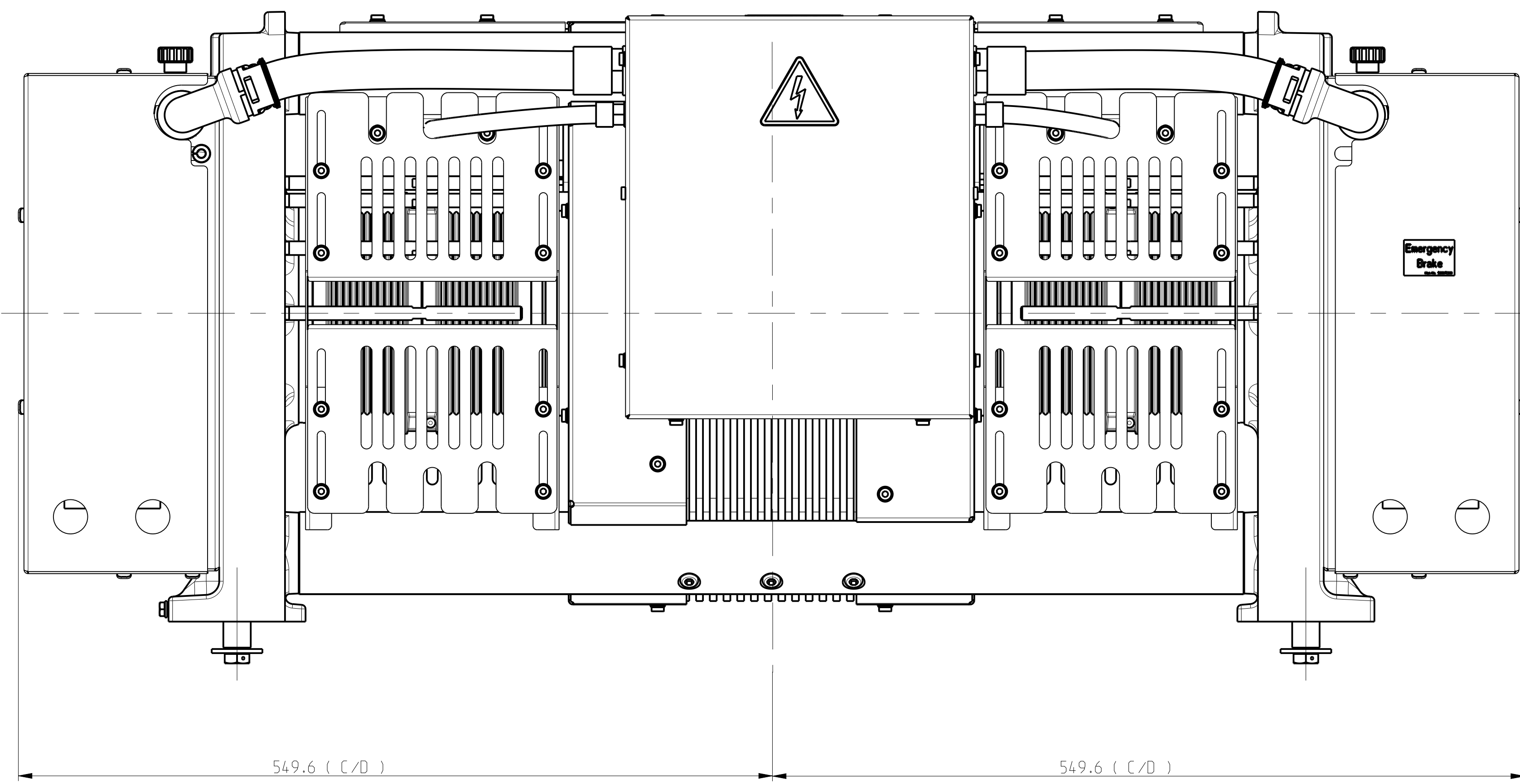

53606000		Serial No.		Serial No.		Material		Material		Material		Material		Material	
DR FML 200		Gearless Drive		NS1		1:1		Z_41604400		EN		NS1		Z_41604400	

Confidential
 This document contains confidential information that is proprietary to the Schneider Group. Neither this document nor the information contained herein shall be disclosed to third parties nor used for manufacturing or any other application without written consent of INVENTIO AG.

Vertraulich
 Dieses Dokument enthält vertrauliche Informationen, die geistiges Eigentum der Schneider-Gruppe sind. Die in diesem Dokument enthaltenen Informationen dürfen weder Dritten noch Dritten ohne schriftliches Einverständnis der INVENTIO AG weder Dritten noch Dritten weitergegeben oder für die Fertigung oder sonstigen Zwecke verwendet werden, ohne die schriftliche Zustimmung der INVENTIO AG.

Confidential
 Ce document contient des informations confidentielles qui sont la propriété de Schneider Electric. Ce document, et les informations contenues dans ce document ne doivent être divulgués à des tiers sans la permission écrite de la Schneider Group.