

Section view  
A-A  
(2:1)

Add Sticker with following informations:  
 -Manufacturer's name : ....  
 -Lamp type: Line  
 -Schindler ID. No. 59392806  
 -Constant current type  
 -Nominal current : 175mA  
 -Nominal power consumption : 7.9W

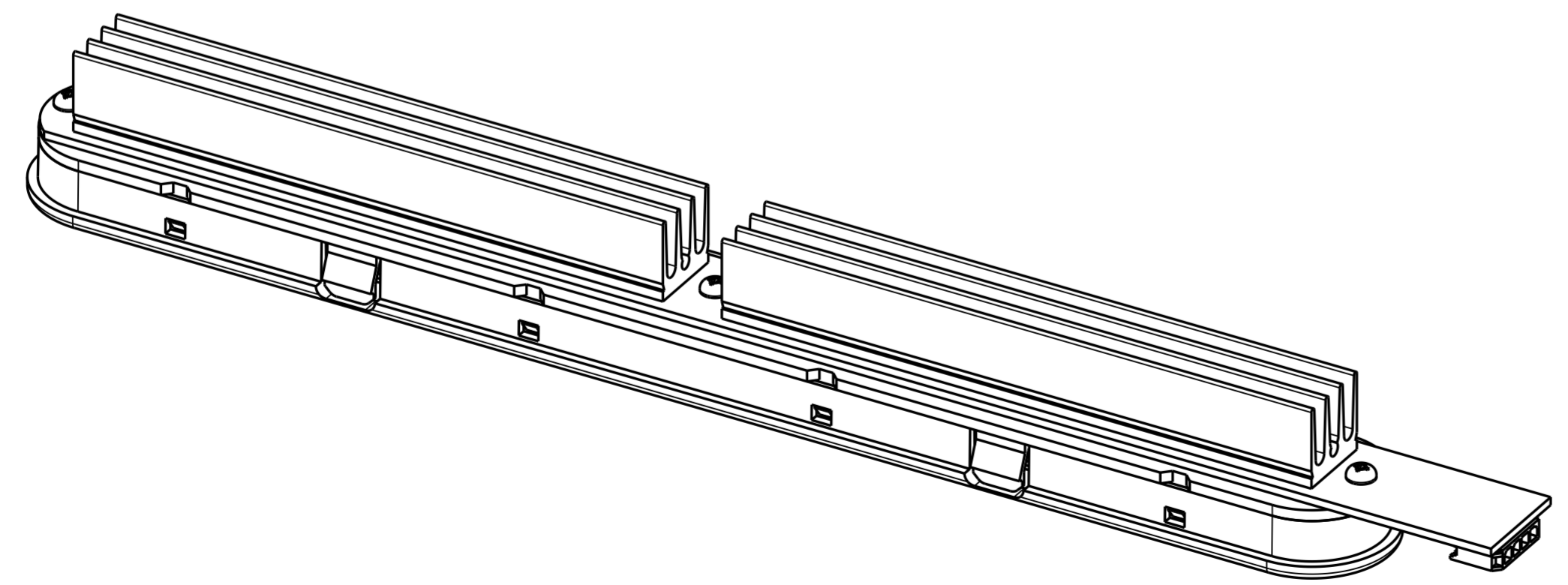

59392806							0.343		
Ident. No.	Semi finished product / raw material	Semi fin. Ident. No.	Item	Code surface	Heat treatment	Drwg / BOM / Model	Weight Kg.		
Modification			Ae0	Draw Ver.					
KA No.			148647	17					
KA Date			2017-09-30	Model Ver.					
				19	Released	Released			
Group: 01					Remark				
Line Lamp cpl.					Scale	Replaces /Ae:	Prepared	Date	Name
					1:1		Reviewed	2017-08-04	hagawani
Release 2					Page 1/1	Norms checked	Released	2017-08-04	strebere
							Released	2017-08-04	nitschto
INVENTIO AG CH-6052 Hergiswil			Classification 11510	Lead Office EB3	Z__59392806		Lang. EN		
			Format A2						

This presentation is our intellectual property. Without our written consent, it shall neither be copied in any manner, nor used for manufacturing, nor communicated to third parties.

Diese Darstellung ist unser geistiges Eigentum. Sie darf ohne unsere schriftliche Zustimmung weder irgendwie kopiert noch zur Anfertigung des Werkes gebraucht oder Drittpersonen bekanntgegeben werden.

Cet ouvrage est notre propriété intellectuelle. Sans notre autorisation écrite, il ne peut être ni copié d'une manière quelconque, ni être utilisé pour la fabrication, ni non plus être communiqué à des tiers.