

General tolerances	ISO 2768	Forming	>120	≤120	Separating
Linear dimension	9-32312E	m	c	c	m
Broken edges		v	c	c	
Angular dimension					
Form and position	9-32313E	L			K
General tolerances DIN6930-m					
Steel stampings 9-32316E					

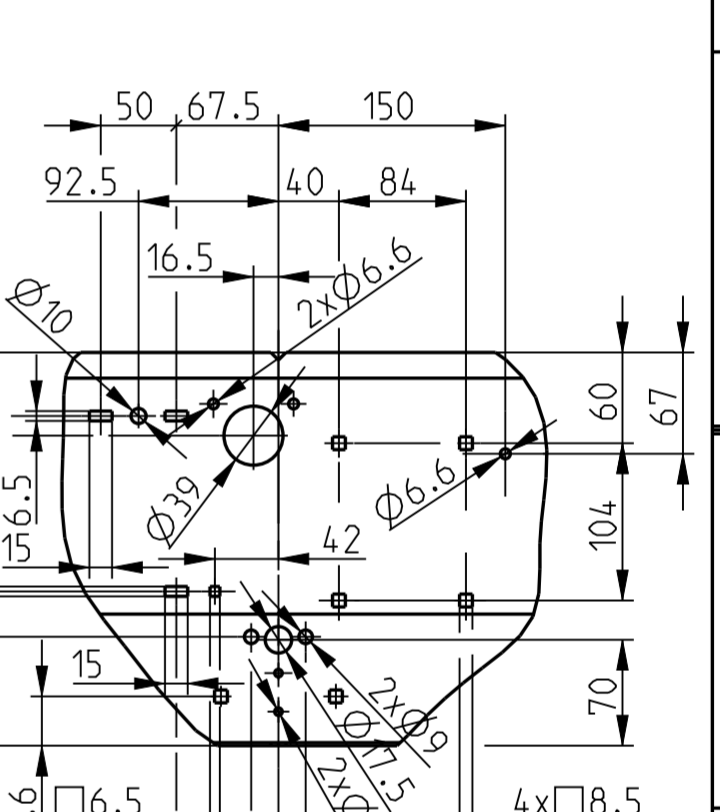

Master for all zones and holes,  
 - except roof fixings holes for brackets  
 - if BKE >=1000  
 - if used for all BKE's to PK32 (front fixation)  
 \* if its for ZLA: measure minus 20mm  
 \* if its for NA (only 1067): measure minus 20mm  
 \*\* only required in BKE length

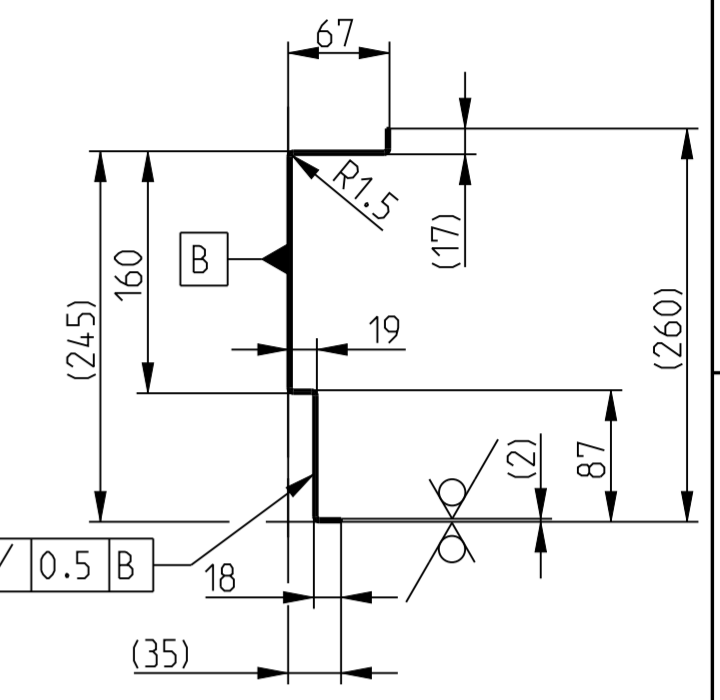
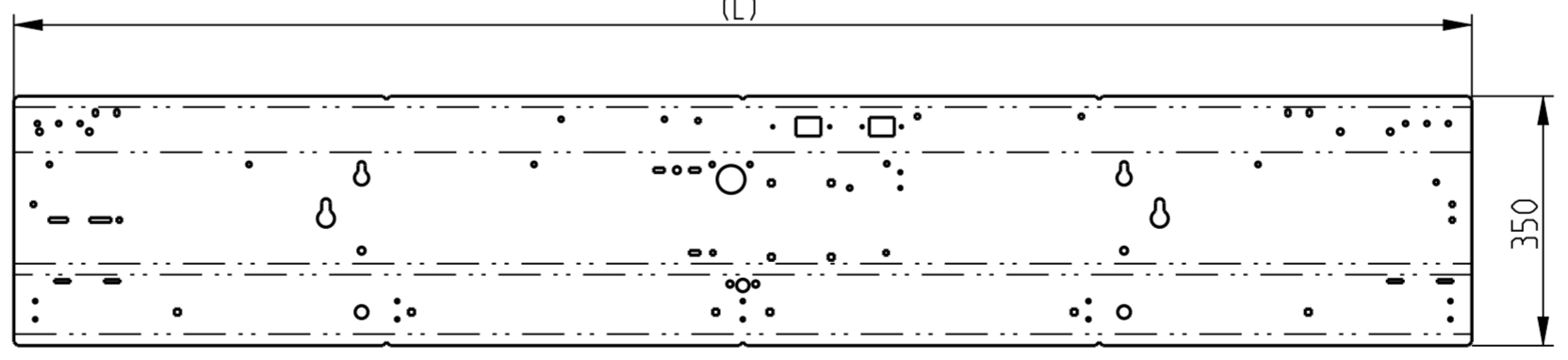
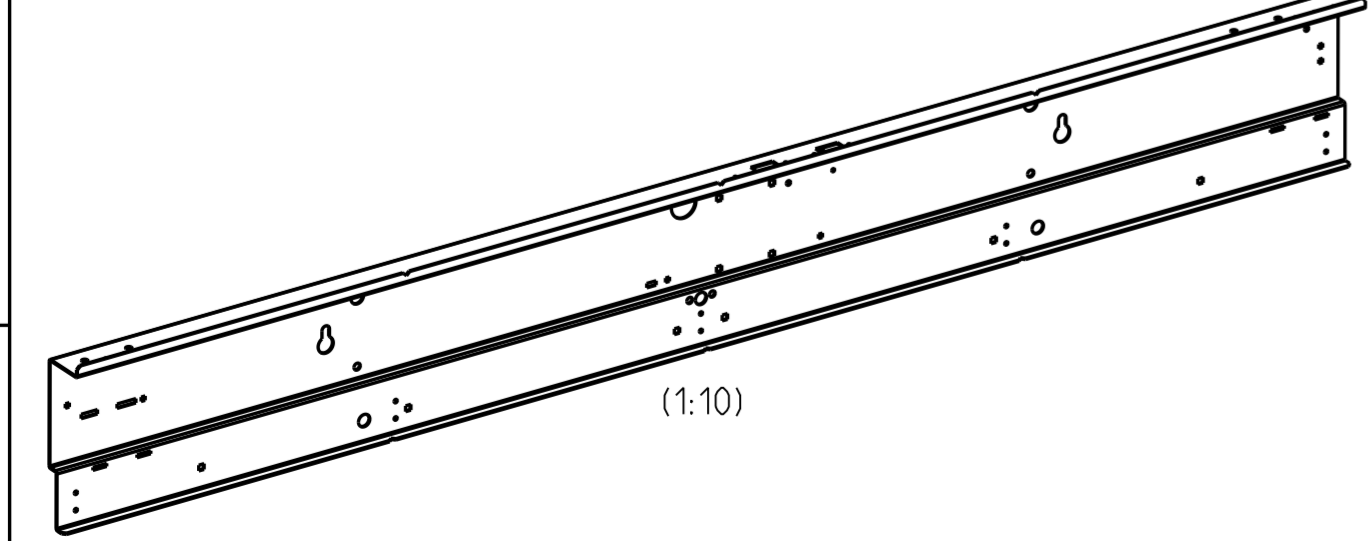

ID No. for C2	BKE	L 2xBKE+46 (ZLA or NA: 2xBKE+6)	A BKE-206.5	B BKE/2 -15	C BKE/2+35	D BKE/2-35
59355131	800	1646	593.5	385	435	365
59355135	800	1606 (ZLA)	593.5	385	435	365
59355132	900	1846	693.5	435	485	415
59355136	900	1806 (ZLA)	693.5	435	485	415
59353333	1000	2046	793.5	485	535	465
59353332	1067	2140 (NA)	860.5	518.5	568.5	498.5
59353331	1100	2246	893.5	535	585	515

Notes:  
 - Parts drawn according to bending process mentioned on N 942449E  
 - All sharp edges removed  
 - Not dimensioned chamfer 5x45°

59353333	Sheet 2 mm on comm. according J_59355150	59355150					11.172
Ident. No.	Semi finished product / raw material	Semi fin. Ident. No.	Item	Code surface	Heat treatment	Drwg / BOM / Model	Weight Kg.
Modification				Ae14	Draw Ver. 7	Related BOM	
KA No.			156999			Related BOM	
KA Date			2020-05-16	Model Ver. 8		Release Level	Released
Group: 01		Remark		Date		Name	
Transom sheet C2		Scale 1:5		Prepared 2020-03-11		hongjeff	
DO VAR 15		Replaces /Ae:		Reviewed 2020-03-12		christju	
		Page 1/5		Norms checked 2020-03-12		christju	
				Released 2020-03-13		zindelda	
INVENTIO AG CH-6052 Hergiswil			Classification 114 30	Lead Office EU1	Z_41354015		Lang. EN
			Format A2				

ID No. for C2	BKE	L 2xBKE+46
59353305	800	1646

Transom BKE800,  
fixing position for brackets (roof fixation)  
if used in zone EU/IND

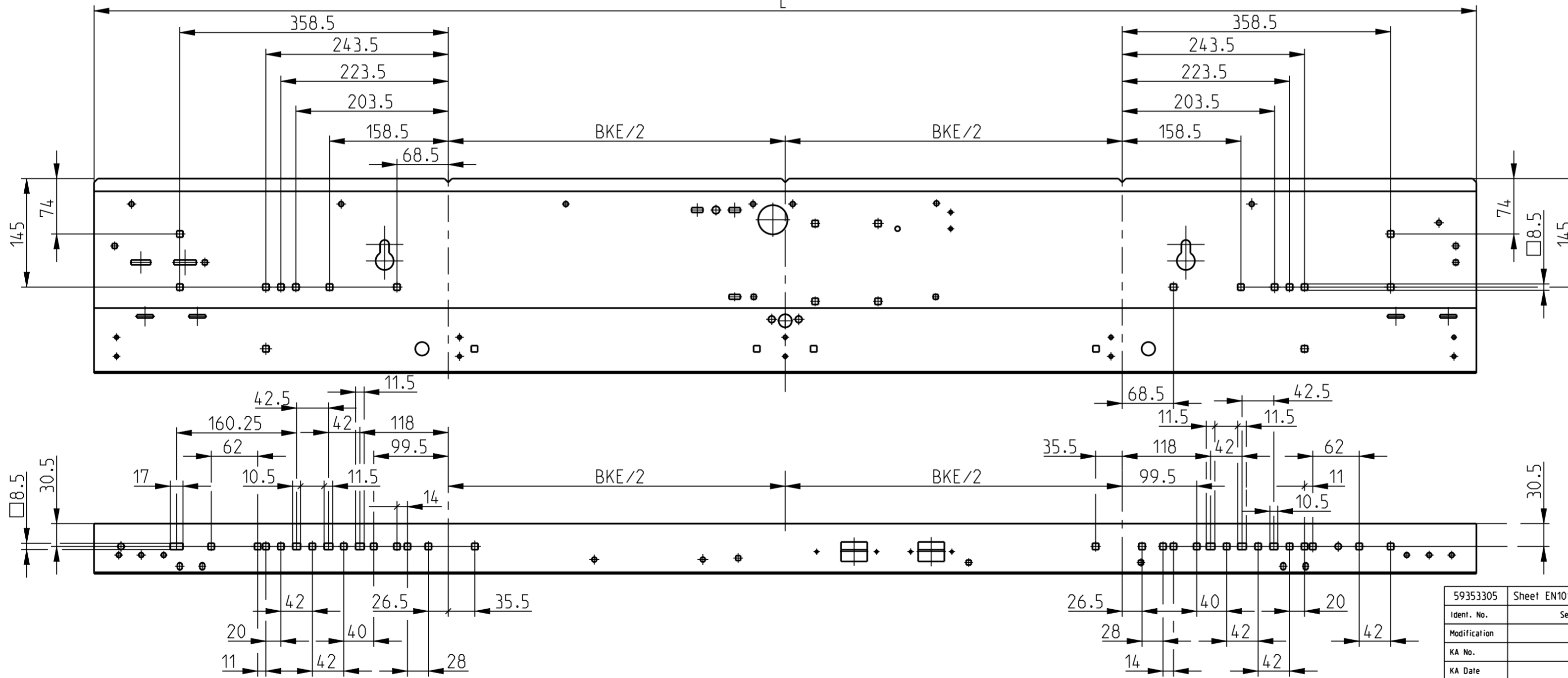
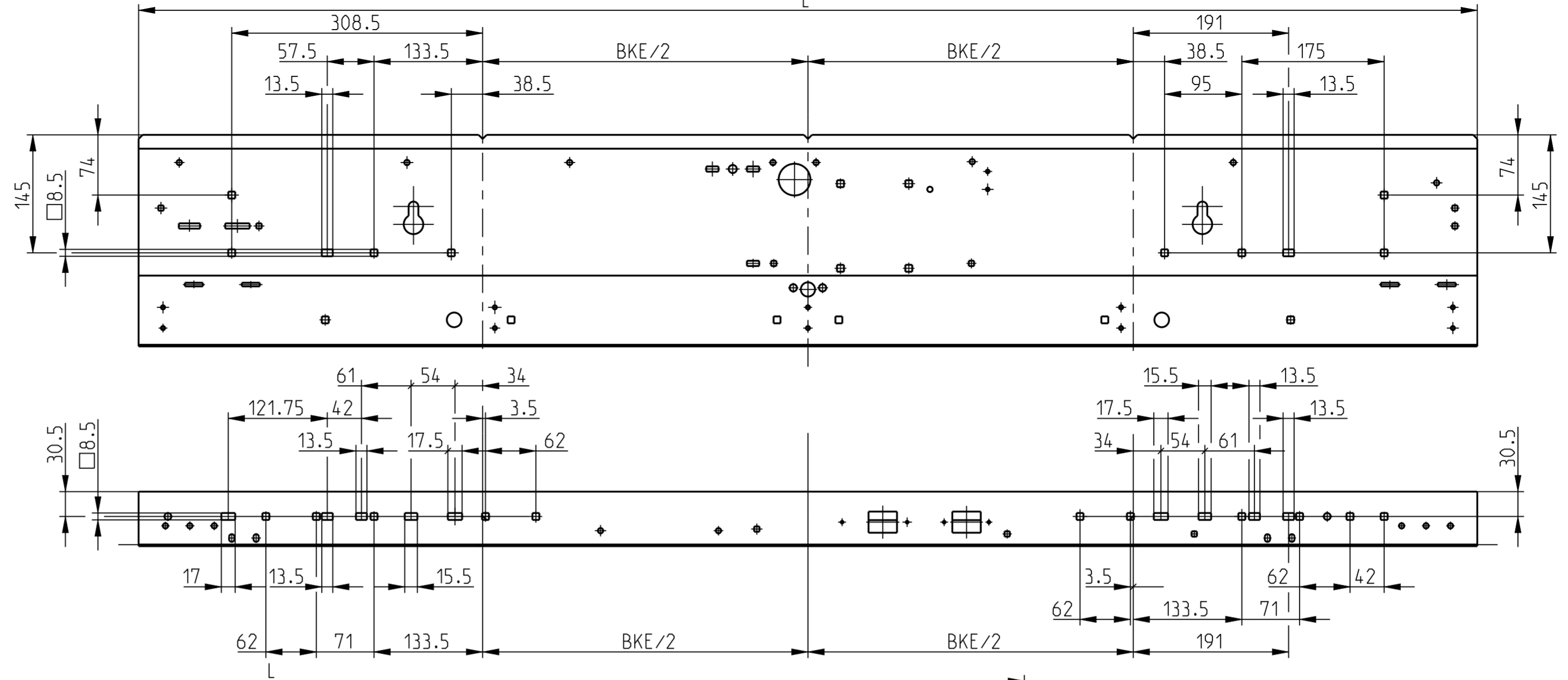

ID No. for C2	BKE	L 2xBKE+46
59353334	900	1846

Transom BKE900,  
fixing position for brackets (roof fixation)  
if used in zone EU/IND

All other BKE's for EU/IND  
are Front fixation, please see page one

General tolerances DIN6930-m  
Steel stampings 9-32316E

General tolerances	ISO 2768	Forming		Sepa- rating
		>120	≤120	
Linear dimension	9-32312E	m	c	m
Broken edges		c	c	
Angular dimension		v	c	
Form and position	9-32313E	L	K	

Notes:

- Parts drawn according to bending process mentioned on N 942449E

√Ra 12.5 (✓)

59353305	Sheet EN10143-2-S250GD-Z275-N-A-C	997170					8.932
Ident. No.	Semi finished product / raw material	Semi fin. Ident. No.	Item	Code surface	Heat treatment	Drwg / BOM / Model	Weight Kg.
Modification			Ae14	Draw Ver.	Related BOM		
KA No.			156999	7	Related BOM		
KA Date			2020-05-16	Model Ver.	Related BOM		
				8	Release Level	Released	
Group: 01		Remark		Date	Name		
Transom sheet C2		Scale 1:5	Replaces /Ae:	Prepared	2020-03-11	hongjeff	
DO VAR 15		Page 2/5		Reviewed	2020-03-12	christju	
				Norms checked	2020-03-12	christju	
				Released	2020-03-13	zindeltda	
INVENTIO AG CH-6052 Hergiswil			Classification 114 30	Lead Office EU1	Z__41354015		Lang. EN

Copyright © 2017 INVENTIO AG All rights reserved.  
INVENTIO AG, Seesrasse 55, CH-6052 Hergiswil, owns and retains all copyrights and other intellectual property rights in this document. Any reproduction, translation, copying or storing in data processing units in any form or by any means without prior permission of INVENTIO AG is regarded as infringement and will be prosecuted.

Confidential  
This document contains confidential information that is proprietary to the Schindler Group. Neither this document nor the information contained herein shall be disclosed to third parties nor used for manufacturing or any other application without written consent of INVENTIO AG.

Vertraulich  
Dieses Dokument enthält vertrauliche Informationen, die geistiges Eigentum der Schindler-Gruppe sind. Die in diesem Dokument enthaltenen Informationen dürfen ohne schriftliches Einverständnis der INVENTIO AG weder Dritten gegenüber offengelegt noch für die Fertigung oder sonstigen Zwecken verwendet werden.

Confidential  
Le présent document contient des informations confidentielles qui sont la propriété du groupe Schindler. Aucune de ces informations ne doit être divulguée à des tiers, ou utilisées à des fins de fabrication sans l'accord écrit de INVENTIO AG.

秘密  
本文件包含集团内部专有信息。未经 INVENTIO AG 许可，不得向任何第三方披露，也不得用于生产目的或其他用途。

ID No. for C2	BKE	L 2xBKE+6
59355133	800	1606

Transom BKE800,  
fixing position for brackets (roof fixation)  
if used in zone ZLA

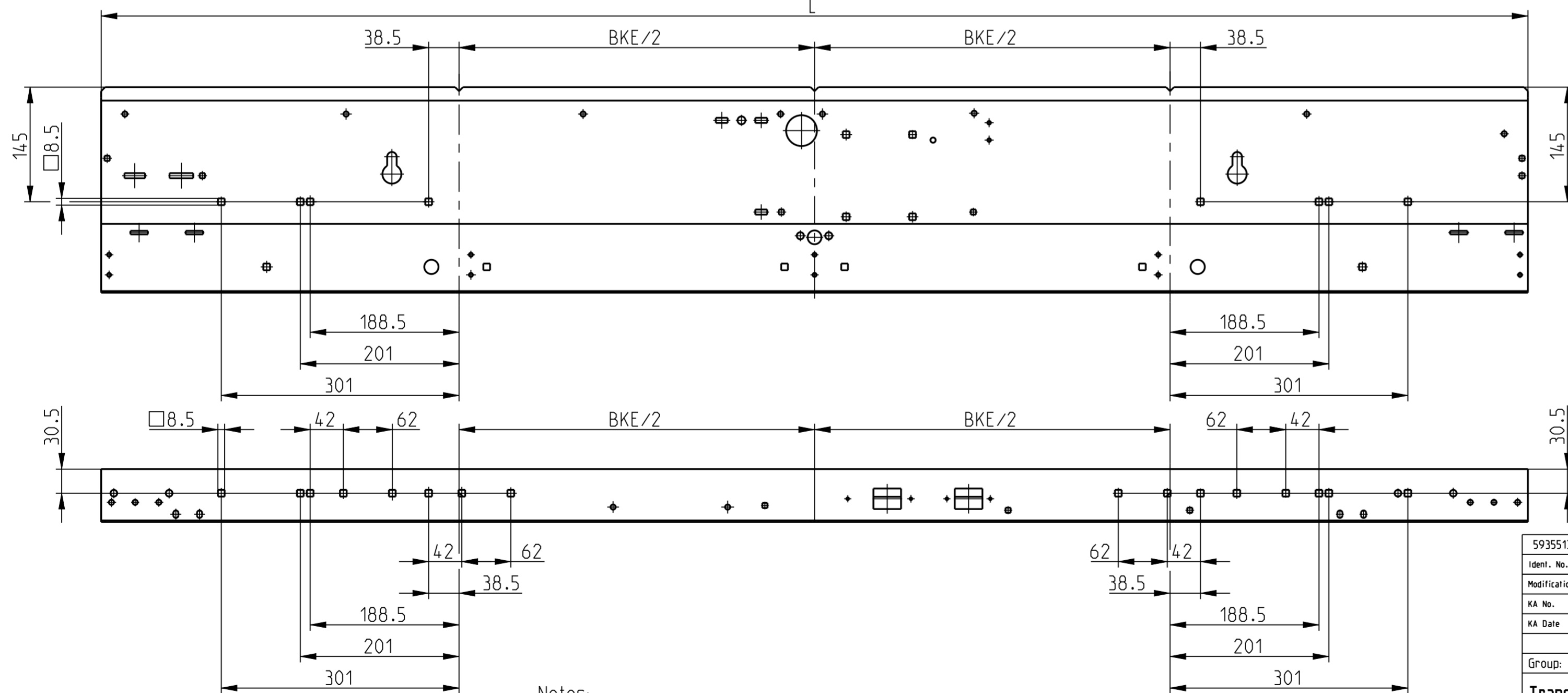
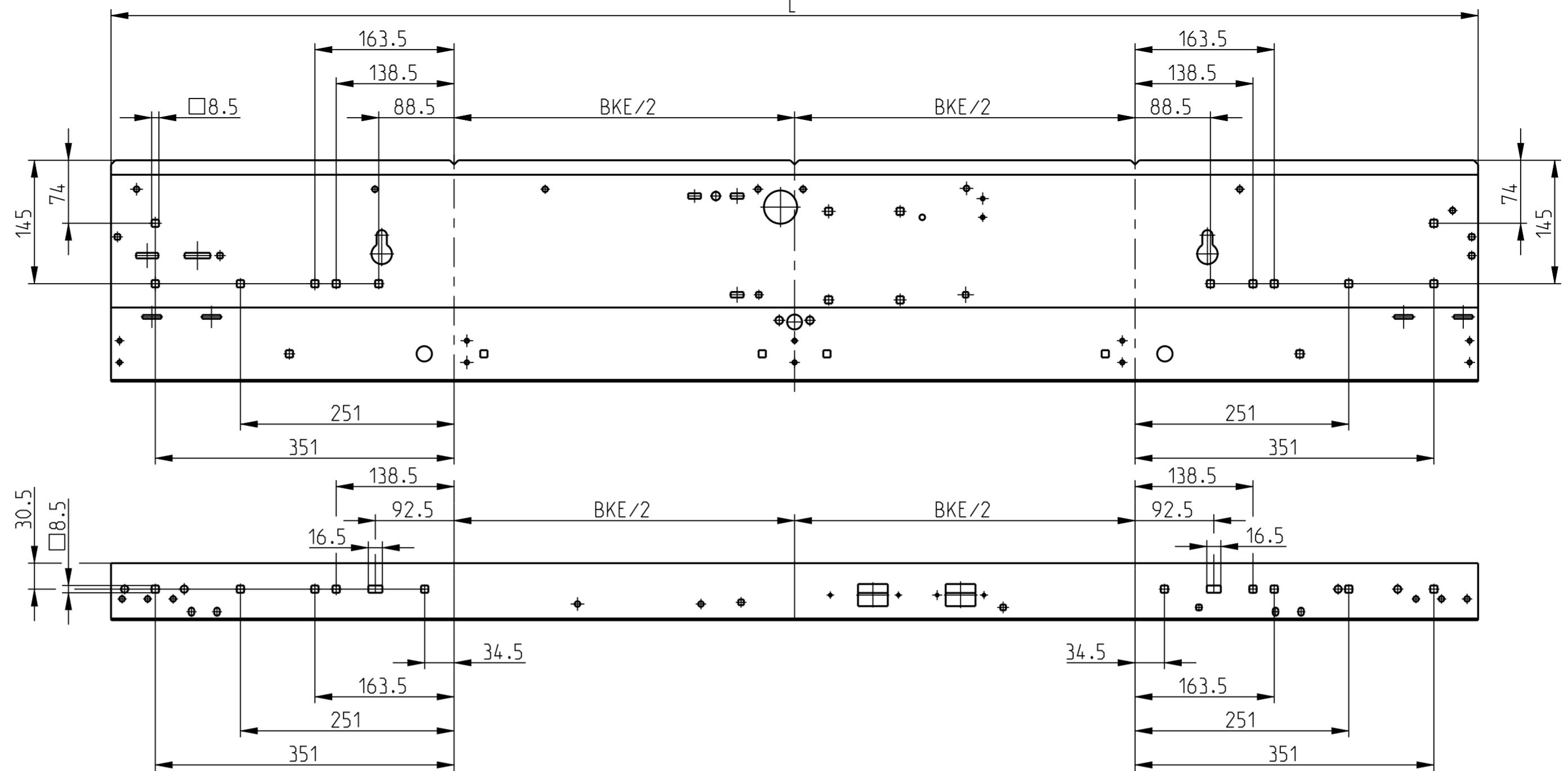

ID No. for C2	BKE	L 2xBKE+6
59355134	900	1806

Transom BKE900,  
fixing position for brackets (roof fixation)  
if used in zone ZLA

All other BKE's for ZLA  
are Front fixation, please see page one

General tolerances DIN6930-m

Steel stampings 9-32316E

General tolerances	ISO 2768	Forming		Sepa- rating
		>120	±120	
Linear dimension	9-32312E	m	c	m
Broken edges		c	c	
Angular dimension	9-32313E	v	c	K
Form and position		L	K	

Notes:

- Parts drawn according to bending process mentioned on N 942449E

$\sqrt{Ra\ 12.5}$

59355133	Sheet 2 mm on comm. according J_59355150	59355150					8.723
Ident. No.	Semi finished product / raw material	Semi fin. Ident. No.	Item	Code surface	Heat treatment	Drwg / BOM / Model	Weight Kg.
Modification			Ae14	Draw Ver. 7	Related BOM		
KA No.			156999	Model Ver. 8	Related BOM		
KA Date			2020-05-16	Release Level	Released		
Group: 01				Remark		Date	Name
Transom sheet C2				Scale 1:5	Replaces /Ae:	Prepared 2020-03-11	hongjeff
DO VAR 15				Page 3/5	Norms checked	Reviewed 2020-03-12	christju
INVENTIO AG CH-6052 Hergiswil				Classification 114 30	Lead Office EU1	Released 2020-03-13	christju
				Format A2		Released 2020-03-13	zindeldda
							Lang. EN
Copyright © 2017 INVENTIO AG All rights reserved. INVENTIO AG, Seesrasse 55, CH-6052 Hergiswil, owns and retains all copyrights and other intellectual property rights in this document. Any reproduction, translation, copying or storing in data processing units in any form or by any means without prior permission of INVENTIO AG is regarded as infringement and will be prosecuted.							

Confidential  
This document contains confidential information that is proprietary to the Schindler Group. Neither this document nor the information contained herein shall be disclosed to third parties nor used for manufacturing or any other application without written consent of INVENTIO AG.

Vertraulich  
Dieses Dokument enthält vertrauliche Informationen, die geistiges Eigentum der Schindler-Gruppe sind. Die in diesem Dokument enthaltenen Informationen dürfen ohne schriftliches Einverständnis der INVENTIO AG weder Dritten gegenüber offengelegt noch für die Fertigung oder sonstigen Zwecke verwendet werden.

Confidentiel  
Le présent document contient des informations confidentielles qui sont la propriété du groupe Schindler. Ni ce document, ni les informations contenues dans ce dernier ne doivent être divulguées à des tiers, ni utilisées à des fins de fabrication sans l'autorisation écrite de INVENTIO AG.

秘密  
本文件包含集团内部专有信息。未经 INVENTIO AG 书面同意，本文件及其所含信息不得向任何第三方披露，也不得用于生产目的或任何其他用途。

ID No. for C2	BKE	L 2xBKE+46
59355137	800	1646

Transom BKE800,  
fixing position for brackets (roof fixation)  
if used in zone AP

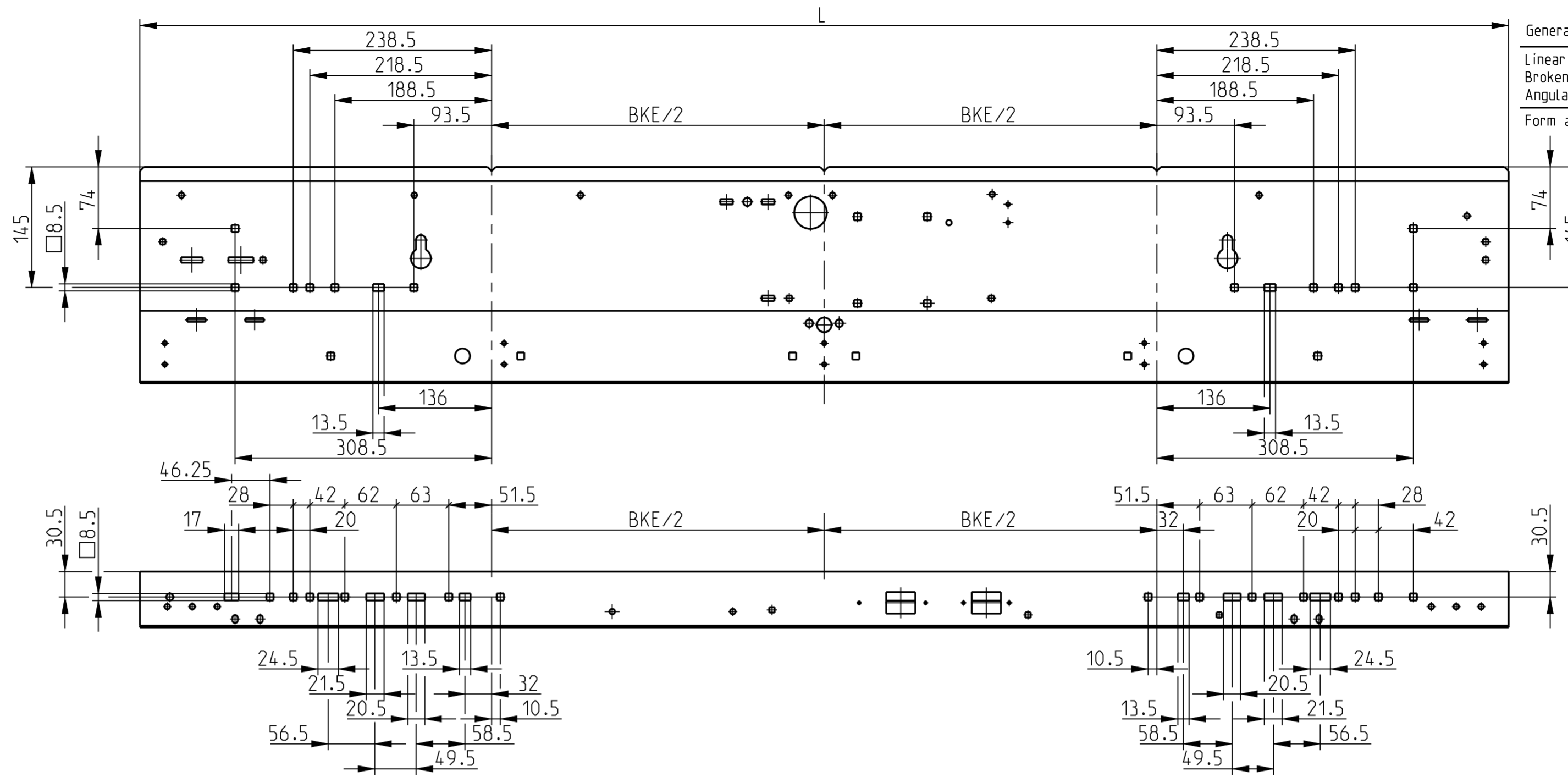

General tolerances	ISO 2768	Forming	>120	±120	Separating
Linear dimension		m	c	c	m
Broken edges	9-32312E	v	c	c	
Angular dimension					
Form and position	9-32313E	L			K

General tolerances DIN6930-m  
Steel stampings 9-32316E

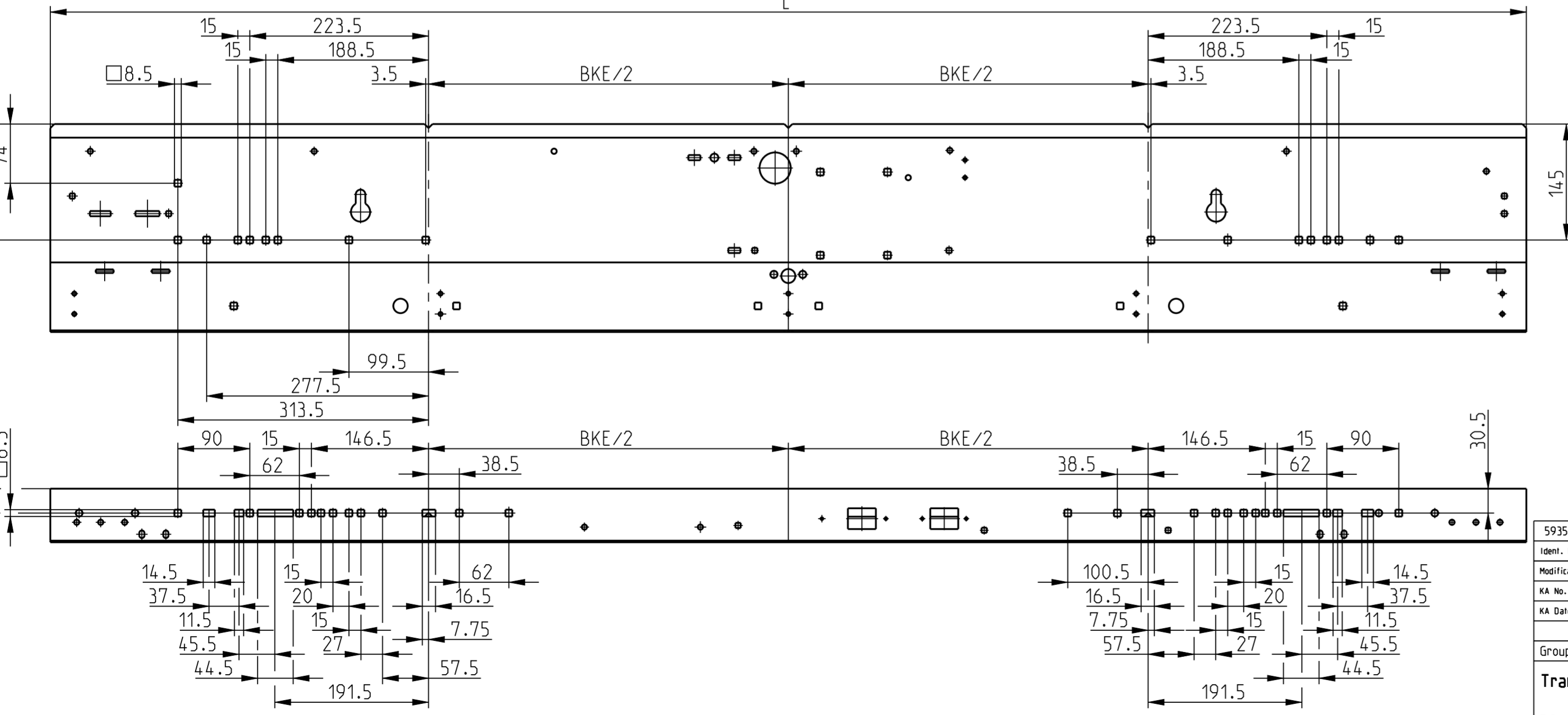

ID No. for C2	BKE	L 2xBKE+46
59355138	900	1846

Transom BKE900,  
fixing position for brackets (roof fixation)  
if used in zone AP

All other BKE's for AP  
are Front fixation, please see page one

√ Ra 12.5 (✓)

Notes:  
- Parts drawn according to bending process mentioned on N 942449E

59355137							8.918
Ident. No.	Semi finished product / raw material	Semi fin. Ident. No.	Item	Code surface	Heat treatment	Drwg / BOM / Model	Weight Kg.
Modification			Ae14	Draw Ver. 7	Related BOM		
KA No.			156999	Model Ver. 8	Related BOM		
KA Date			2020-05-16	Release Level	Released		
Group: 01		Remark		Date	Name		
Transom sheet C2		Scale 1:5	Replaces /Ae:	Prepared 2020-03-11	hongjeff		
DO VAR 15		Page 4/5	Norms checked	Reviewed 2020-03-12	christju		
INVENTIO AG CH-6052 Hergiswil		Classification 114 30	Lead Office EU1	Released 2020-03-13	zindeldda		
		Format A2				Lang. EN	
Copyright © 2017 INVENTIO AG All rights reserved. INVENTIO AG, Seesstrasse 55, CH-6052 Hergiswil, owns and retains all copyrights and other intellectual property rights in this document. Any reproduction, translation, copying or storing in data processing units in any form or by any means without prior permission of INVENTIO AG is regarded as infringement and will be prosecuted.							

Confidential  
This document contains confidential information that is proprietary to the Schindler Group. Neither this document nor the information contained herein shall be disclosed to third parties nor used for manufacturing or any other application without written consent of INVENTIO AG.

Vertraulich  
Dieses Dokument enthält vertrauliche Informationen, die geistiges Eigentum der Schindler-Gruppe sind. Die in diesem Dokument enthaltenen Informationen dürfen ohne schriftliches Einverständnis der INVENTIO AG weder Dritten gegenüber offengelegt noch für die Fertigung oder sonstigen Zwecke verwendet werden.

Confidential  
Le présent document contient des informations confidentielles qui sont la propriété du groupe Schindler. Ni ce document, ni les informations contenues dans ce dernier ne doivent être divulgués à des tiers ni utilisés à des fins de fabrication sans l'accord écrit de INVENTIO AG.

警告  
本文件包含集团机密信息。未经 INVENTIO AG 许可，本文件及其所含信息不得向任何第三方披露，也不得用于生产目的或其他用途。

General tolerances ISO 2768		Forming		Sepa- rating
		>120	±120	
Linear dimension	9-32312E	m	c	m
Broken edges		v	c	
Angular dimension				
Form and position	9-32313E	L	K	

ID No. for C2	BKE	L 2xBKE+6
59353332	1067	2140

Transom BKE1067,  
fixing position for LVH brackets  
if used in zone NA

General tolerances DIN6930-m  
Steel stampings 9-32316E

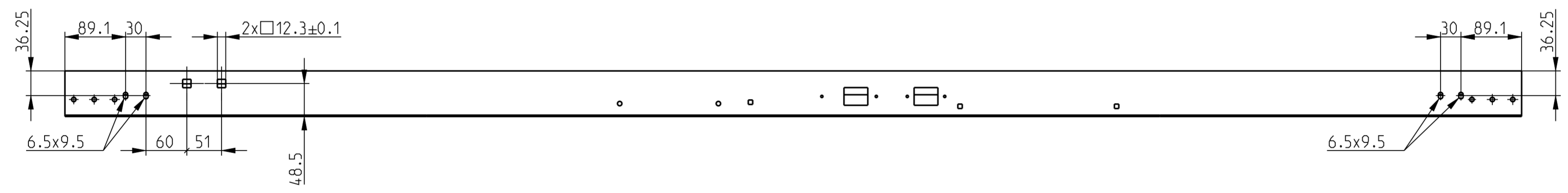
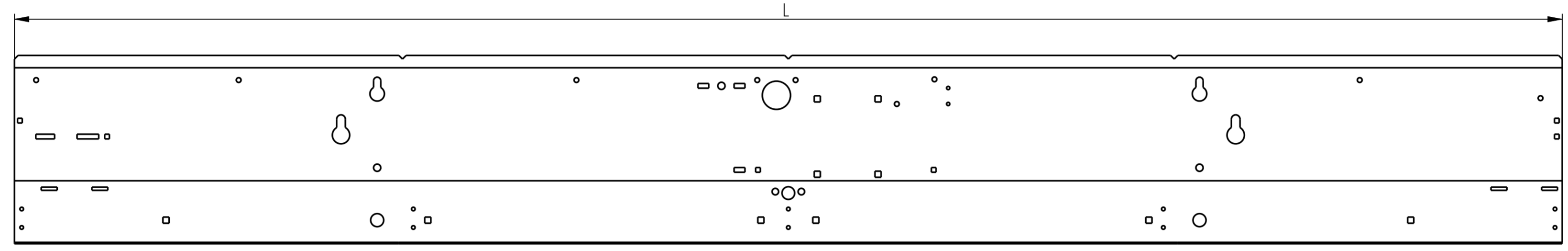

√ Ra 12.5 (✓)

Notes:

- Parts drawn according to bending process mentioned on N 942449E

59355137							8,918	
Ident. No.	Semi finished product / raw material	Semi fin. Ident. No.	Item	Code surface	Heat treatment	Drwg / BOM / Model	Weight Kg.	
Modification				Ae14	Draw Ver. 7	Related BOM		
KA No.				156999	Model Ver. 8	Related BOM		
KA Date				2020-05-16		Release Level	Released	
Group: 01					Remark		Date	Name
Transom sheet C2					Scale 1:1	Replaces /Ae:	Prepared 2020-03-11	hongjeff
DO VAR 15					Page 5/5		Reviewed 2020-03-12	christju
INVENTIO AG CH-6052 Hergiswil					Classification 114 30	Lead Office EU1	Norms checked 2020-03-12	christju
					Format A2		Released 2020-03-13	zindelda
								Lang. EN
Copyright © 2017 INVENTIO AG All rights reserved. INVENTIO AG, Seestrasse 55, CH-6052 Hergiswil, owns and retains all copyrights and other intellectual property rights in this document. Any reproduction, translation, copying or storing in data processing units in any form or by any means without prior permission of INVENTIO AG is regarded as infringement and will be prosecuted.								

Confidential  
This document contains confidential information that is proprietary to the Schindler Group. Neither this document nor the information contained herein shall be disclosed to third parties nor used for manufacturing or any other application without written consent of INVENTIO AG.

Vertraulich  
Dieses Dokument enthält vertrauliche Informationen, die geistiges Eigentum der Schindler-Gruppe sind. Die in diesem Dokument enthaltenen Informationen dürfen ohne schriftliches Einverständnis der INVENTIO AG weder Dritten gegenüber offengelegt noch für die Fertigung oder sonstigen Zwecke verwendet werden.

Confidentiel  
Le présent document contient des informations confidentielles qui sont la propriété du groupe Schindler. Ni ce document, ni les informations contenues dans ce dernier ne doivent être divulguées à des tierces parties, ou utilisées à des fins de fabrication sans l'accord écrit de INVENTIO AG.

秘密  
本文件包含集团内部专有信息。未经 INVENTIO AG 许可，本文件及其所含信息不得向任何第三方披露，也不得用于生产目的或任何其他用途。